



A.E. Randles

Packaging Machinery Since 1957

TRAY & CARTON FORMING MACHINES

STANDARD FEATURES

- “STEEL-IT” BRAND EPOXY PAINTED TUBING FRAME
- 15 MINUTE CHANGEOVER TIME
- 120/220 VAC 1/3 PHASE ELECTRICALS
- CENTRAL LUBE POINTS FOR BEARINGS
- AB POWERFLEX 4 CONTROLLER
- THOMPSON SHAFTS USED FOR LINEAR BUSHING SURFACES
- SAFETY INTERLOCKED “LEXAN” GUARDING AND ACCESS PANELS
- 1/2 HORSEPOWER MOTOR
- BRAKED CASTERS ON ADJUSTABLE LEGS (RAISES 10”)
- REMOTE START / STOP STATION—MOVEABLE UP TO 10’ FROM MACHINE
- 17” OF CARTON BLANKS IN HOPPER
- SPEEDS UP TO 90 CARTONS PER MINUTE DEPENDING ON CARTON AND MACHINE SIZE
- TOOLING IS MADE OF ALL STAINLESS STEEL CONSTRUCTION

OPTIONS

- 480 VAC 3 PHASE ELECTRICALS
- PHOTOEYE OR FOOTSWITCH CONTROL TO BYPASS VACUUM SYSTEM/ CARTON ON DEMAND (SWITCHABLE)
- STAINLESS STEEL FRAME W/ NEMA 4 ELECTRICALS
- HOT MELT GLUE SYSTEMS
- FRAME BASE TO RAISE MACHINE OVER 10”
- START/STOP FOOTSWITCH W/ GUARD
- “TWO UP” OR DOUBLE HEAD SETS OF TOOLING
- SELF CONTAINED VACUUM PUMP OR VENTURI STYLE VACUUM GENERATOR
- EXTENDED/ HIGH CAPACITY HOPPER

TOOLING AVAILABLE FOR:

- LOCK STYLE CARTONS WITH OR WITHOUT LIDS
- GLUED CARTONS WITH OR WITHOUT LIDS
- CHIPBOARD AND/OR CORRUGATED
- HOLLOW WALL OR “FRAME-VIEW” BOXES
- SIMPLEX CARTONS



MACHINE DIMENSIONS

	MODEL NUMBER					
	10-18	9-32	16-26	22-34	22-44	30-48
A	24	39	32	42	52	63
B	60	60	64	69	69	72
C	42	42	56	68	68	90
D	45	45	45	45	45	40
E	12	12	19	23	23	28
F	34	34	33	33	33	24
G	10	10	10	16	16	5

inches

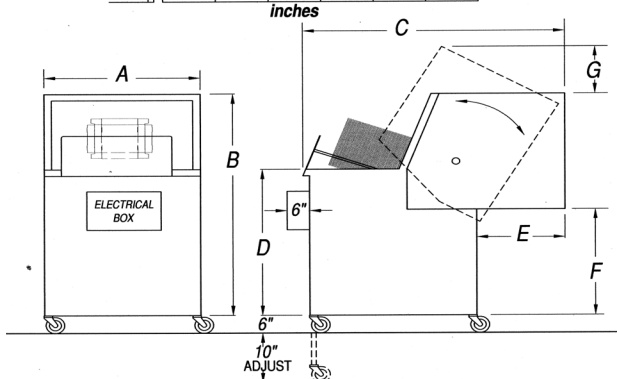

CARTON STYLES

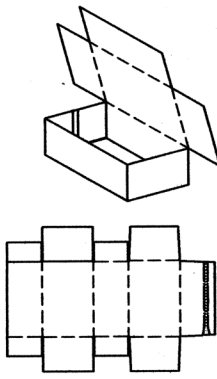
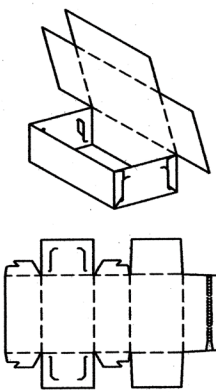
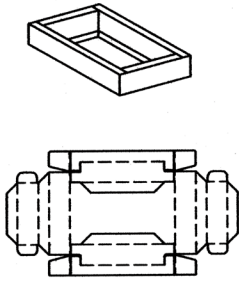
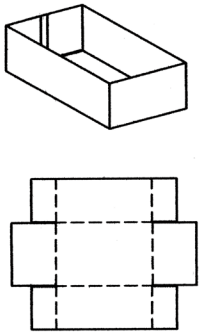
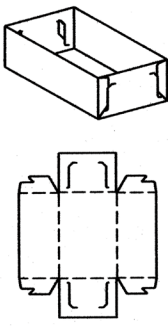
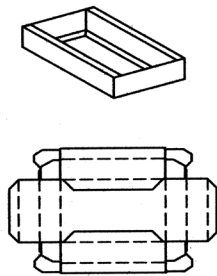
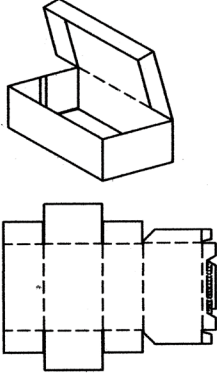
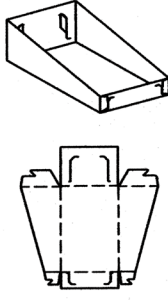
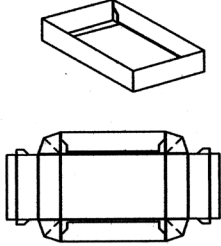
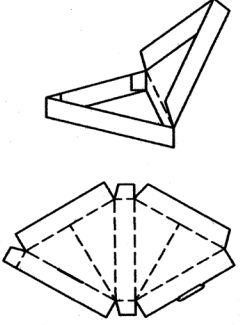
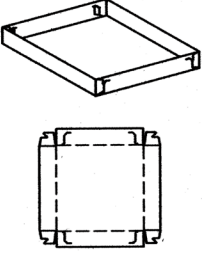
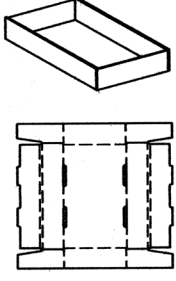
 <p>TOP LOAD GLUE STYLE 3-FLAP</p>	 <p>STRIPPER LOCK 3-FLAP LID</p>	 <p>SIMPLEX FULL FRAME VIEW</p>
 <p>GLUE STYLE TRAY</p>	 <p>STRIPPER LOCK TRAY</p>	 <p>SIMPLEX HALF FRAME VIEW</p>
 <p>TOP LOAD 3-FLAP 'HOODED' GLUE STYLE</p>	 <p>STRIPPER LOCK DISPLAY TRAY</p>	 <p>SIMPLEX CORNER LOCK</p>
 <p>TRIANGULAR WITH HINGED COVER</p>	 <p>STRIPPER LOCK LOW SIDEWALL TRAY</p>	 <p>SIMPLEX BOTTOM LOCK</p>